



LUMIFOG
PRIVATE LIMITED

THE MANIFOLD FOR CHILLED WATER & HOT WATER SUPPLY

**When we build,
we finish.**

**When we commit,
we deliver**

WE FABRICATE

- ▶ **CHILLER MANIFOLD**
- ▶ **AHU MANIFOLD**
- ▶ **PUMP MANIFOLD**
- ▶ **COOLING TOWER MANIFOLD**
- ▶ **FANCOIL UNIT MANIFOLD**



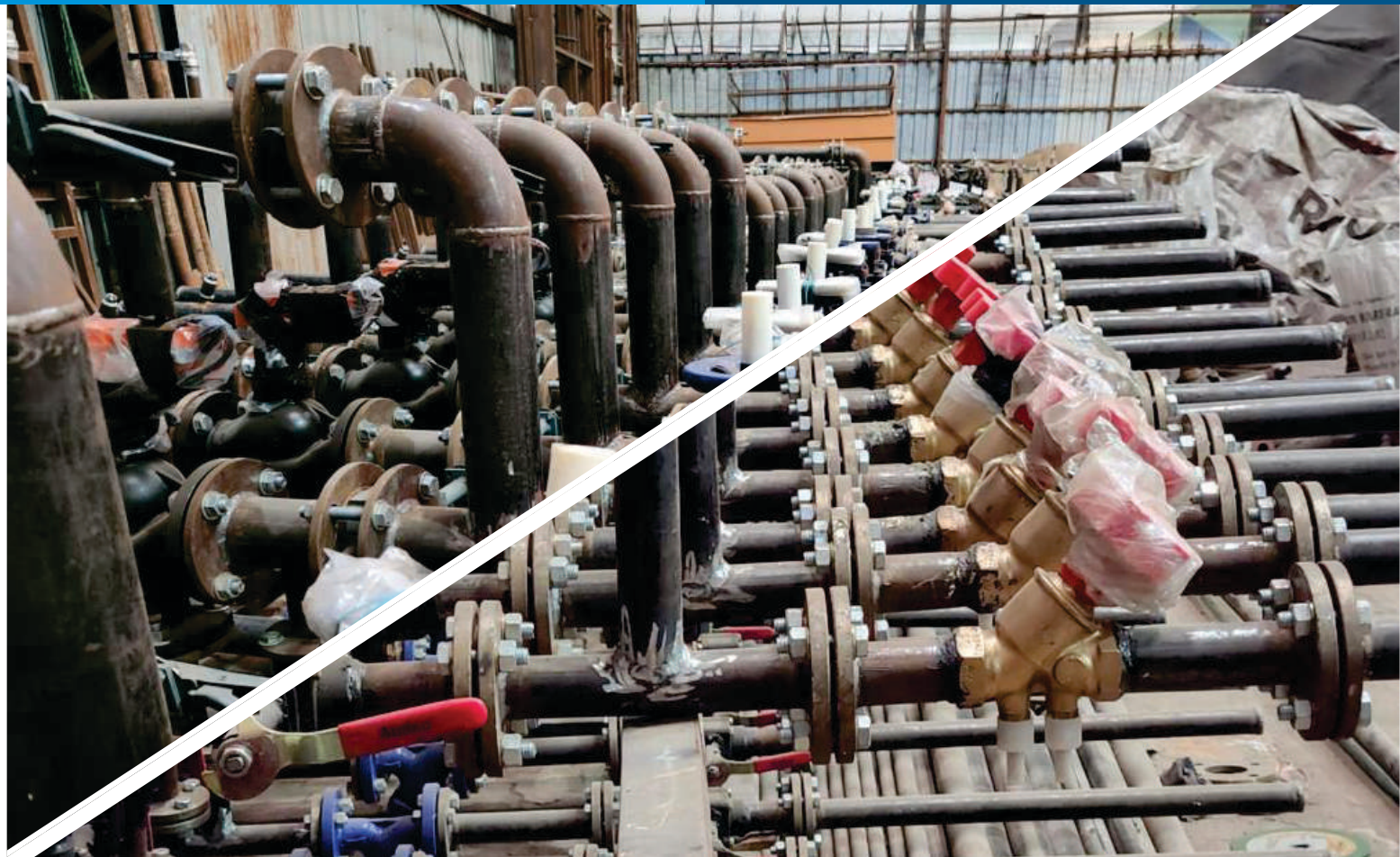

ABOUT US

The development of any big company starts with a first small step. This also applies to **LUMIFOG PVT LTD.** The small company founded in 2017 had nothing to do with manufacturing of **AIR CONDITIONING** Products. At that time **LUMIFOG PVT LTD.** was successful in the fabrication work, achieving considerable success. During those supply problem arose that had to be solved. Good manifold & processing spares were not found. The solution was to make quality manifold & accessories for **CHILLED WATER AND HOT WATER SUPPLY.** One small step, an initial idea that has been consistently expanded upon, leading to an internationally company which continuously drives the **AIR CONDITIONING** industry with new developments.

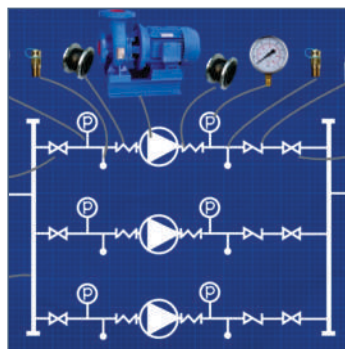



ABOUT US

Quality Products, Quality people and Quality service these three vital ingredients which makes a company renowned are available of LUMIFOG PVT LTD.

We are one of the pioneers in the Manufacturing / Fabrication of Water manifold Supply And Accessories. With the stable of the art Manufacturing /Fabrication facility at our works it makes us more confident and fast to cater market demands in the with the highest level of precision. Our customer network is established at PAN India level which makes it more comfortable for customer to get associated with us and makes us more reliable.

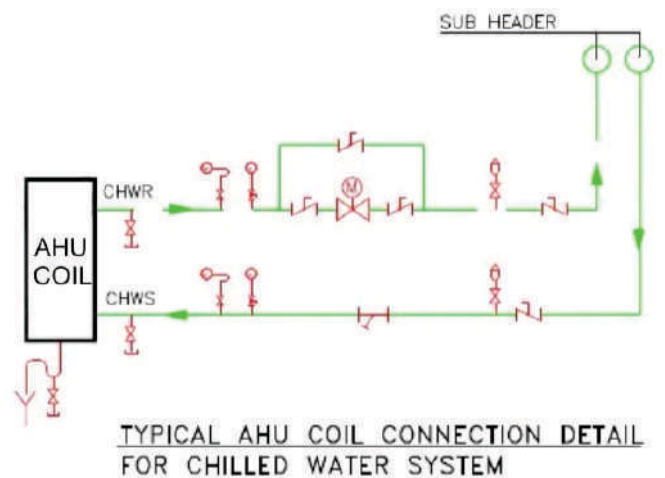

LEGENDS	
	BUTTERFLY VALVE
	BALANCING VALVE
	CHILLED WATER SUPPLY PIPE
	CHILLED WATER RETURN PIPE
	AUTOMATIC AIR VENT WITH BALL VALVE
	REDUCER
	BALL VALVE
	DRAIN VALVE
	HOT WATER SUPPLY PIPE
	HOT WATER RETURN PIPE
	TEMPERATURE GAUGE WITH THERMOWELL
	PRESSURE GAUGE WITH ISOLATION VALVE & SIPHON
CHW	CHILLED WATER
HW	HOT WATER
HWC	HOT WATER COIL

	NON RETURN VALVE
	Y- STRAINER
	MAGNETIC FLOW METER
	PRESSURE INDEPENDENT BALANCING CUM CONTROL VALVE
	3 WAY MOTORISED VALVE

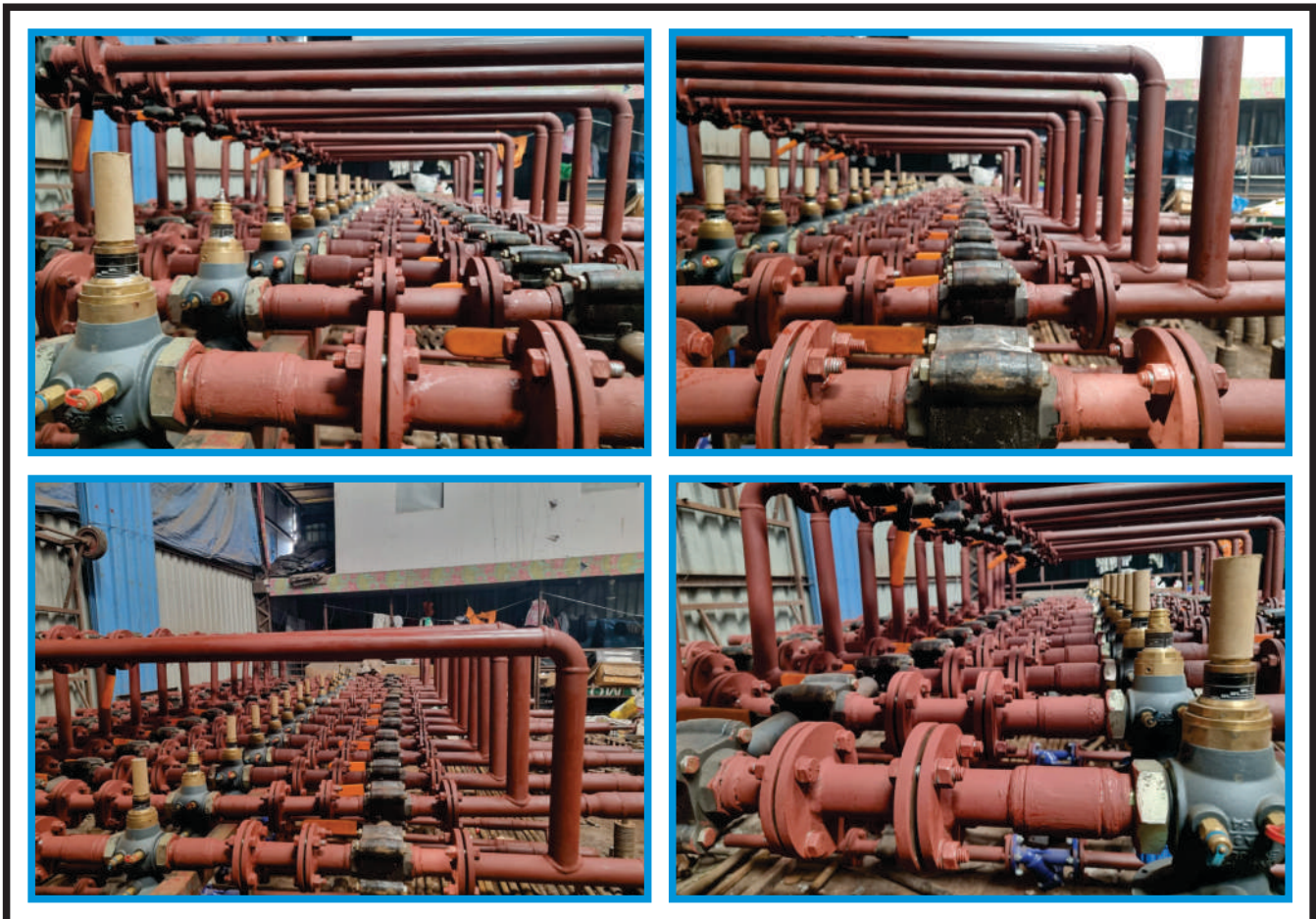

Contact Us

+91 9372348997
Info@lumifog.com
www.lumifog.com

Reg. Office: Office no. 7, Kherani Estate ,
Jangleshwar Mandir Road, Subhash Nagar,
salpha Village, Ghatkopar (W), Mumbai-400084

Operating Office: F-48, 1st Floor,
Kohinoor City Mall, Kirol Road,
Kurla (W), Mumbai-400 070.